

RACK CONVEYOR MACHINES

# AC2 series

Straight to the point.







## **HYGIENE. COMENDA!**

At Comenda, we have been producing professional dishwashers since 1963. Hygiene and Safety are in our DNA.

**All our solutions guarantee the complete sanitisation of the dishware and glassware thanks to thorough washing operations, controlled temperatures and contact times in line with the DIN10534 standard.**

## **TO CLEAN. WITH CARE.**

To Clean. "With Care": our attitude and philosophy that guides us every day to develop products that meet the needs of our customers.

Attention to each detail and care for people are at the hearth of the design of our products, which are developed to offer reduced consumption, maximum performance and a more comfortable work environment.



**The AC2 series rack conveyor dishwashers guarantee maximum efficiency in a space-saving format.**

**Available in both the linear and corner configuration to adapt to any wash up area!**





Comenda AC2 rack conveyor dishwashers combine the power and productivity of large-scale systems with compact size of cycle models and the benefits of automatic solutions.

They ensure maximum **comfort for the operator** and significantly **reduce utilities consumption**.

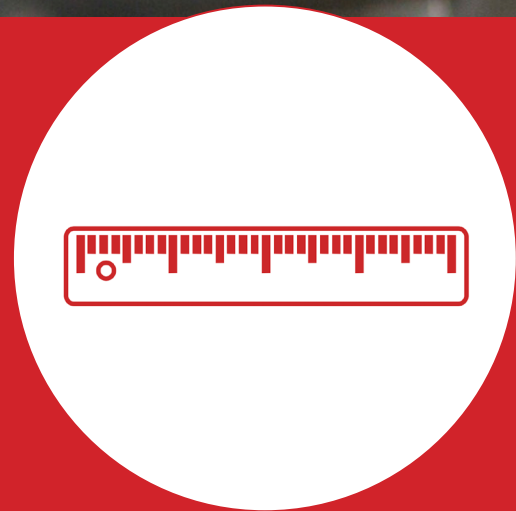

COMPACT IN SIZE



AC2 RACK  
CONVEYOR  
DISHWASHERS



UP TO 150 RACKS/H  
CAPACITY





## WHY CHOOSE AN AUTOMATIC WASHING SOLUTION



**AC2 Series ensures fluid washing operations with ultimate washing results.**

With the same footprint of a double basket hood type machine, AC2 and AC2A units increase the efficiency in your wash up area, eliminating the impact of repetitive actions of the operator - like, for example opening and closing the hood - on the actual capacity of the machine. And no more waiting until there are two racks of dirty dishes before starting the dishwashing cycle.

**Flawless results with the minimal consumption of utilities and chemicals, increasing operator safety and well-being.**

**AC2 units use 2,2 liter of rinse water per rack. Heat recovery passive and active is an option as well as the rinse aid homogeniser.**





## WHY AC2 SERIES?



### SPACE EFFICIENT

If space is a constraint, AC2 is the perfect fit. A wash section and a single rinse section efficiently compacted in a **1150mm module**.



### POWER

With AC2, put theoretical productivity aside and just talk about **real productivity**. **The racks are conveyed automatically and the time it takes the operator to load and unload the racks is significantly reduced!**



### FLEXIBILITY

It is perfect for anyone looking for a highly versatile, modular washing system that **ican meet a variety of applications and workloads**. Available in **linear and corner configurations**.



### ECO-SUSTAINABILITY

A wide range of optional accessories means you can add on **modules like the dryer and heat recovery unit**, which allow you to **optimise consumptions, improve washing results and make the working environment more comfortable**.







## THE SOLUTION FOR EVERY SECTOR

The extreme flexibility of the AC2 series rack conveyor dishwashers makes it an invaluable ally in a wide variety of different businesses and set-ups, which all need to sanitise a large number of dishes and crockery in the shortest possible time, but which have limited space in their washing areas.



Different scenarios with a single solution in common!



SCHOOLS, UNIVERSITIES  
AND CANTEENS



HO.RE.CA



CARE SECTOR





## DESIGNED TO BE BY YOUR SIDE

Our goal is to create washing areas where the operator can move smoothly and comfortably, without any unnecessary or incorrect movements.

**The AC2 series is simple to use and service.**

A full set of scrapping stations, prewash and exit tables, side loaders and unloaders complete the setup. They are **designed to minimise the risk of contamination** between dirty and clean items during the service phases.

They make life easier for the operator when loading and unloading the racks, by helping to **avoid incorrect movements** and **preventing the onset of muscular-skeletal disorders**.

**Reversible feed** as a standard feature for models AC2 and AC2A in their basic execution. The feeding direction can be adjusted during installation.

## THE SOLUTION AROUND THE CORNER

Available in linear (AC2) and corner (AC2A) configurations, they guarantee excellent performance in a space-saving format.







## REASONS TO CHOOSE THE PRE-WASH

An efficient pre-wash means cleaner water in the tank, deeper hygiene inside the washing chamber and, therefore, better results.

## GREATER PRODUCTIVITY

Thanks to the "P" additional prewash module, improved washing results translate in a remarkable 50% increase in productivity: from up to 100 racks/h with an AC2 / AC2A to up to 150 racks/h with AC2P / AC2AP.

## INTEGRATED PRE-WASH MODULE

The 500mm P prewash module is available for both AC2 and AC2A units.

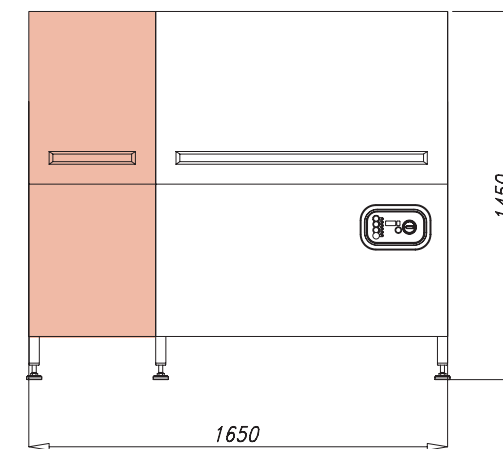
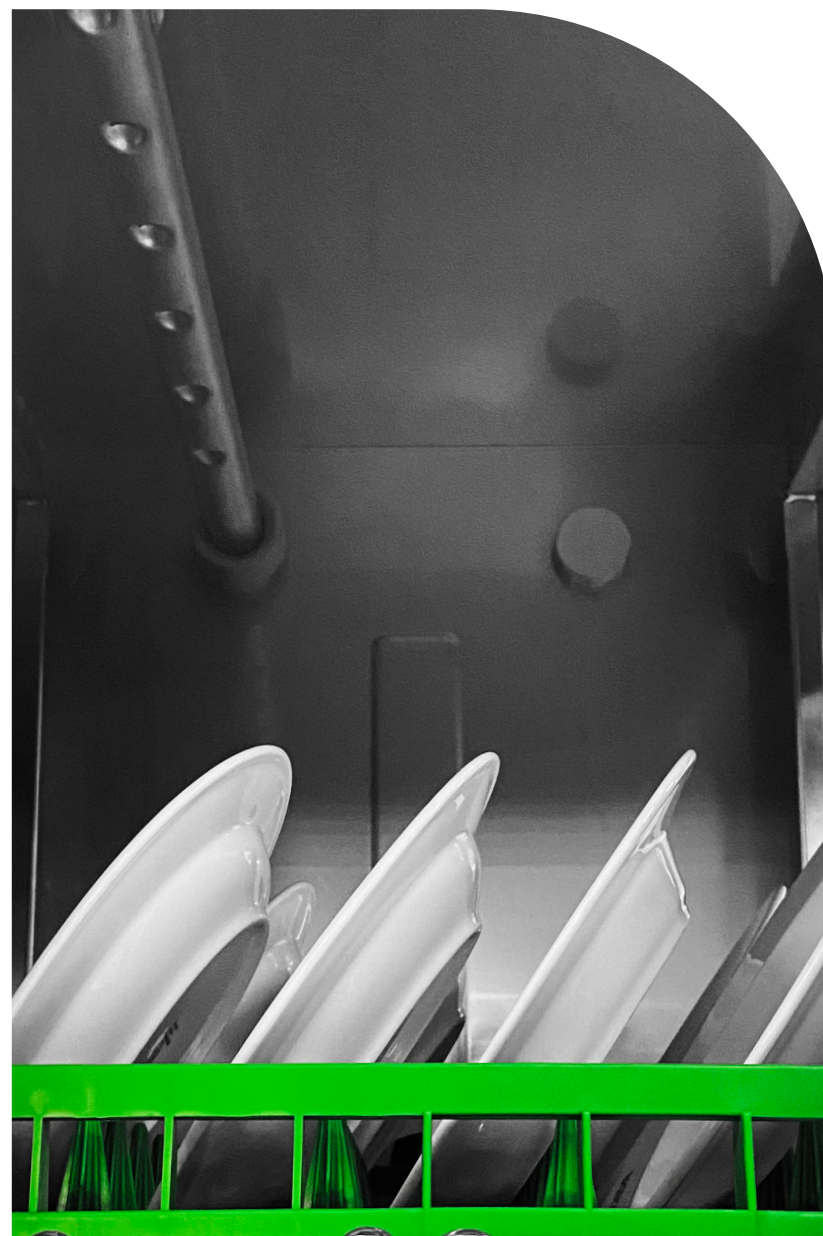

AC2P - Straight configuration

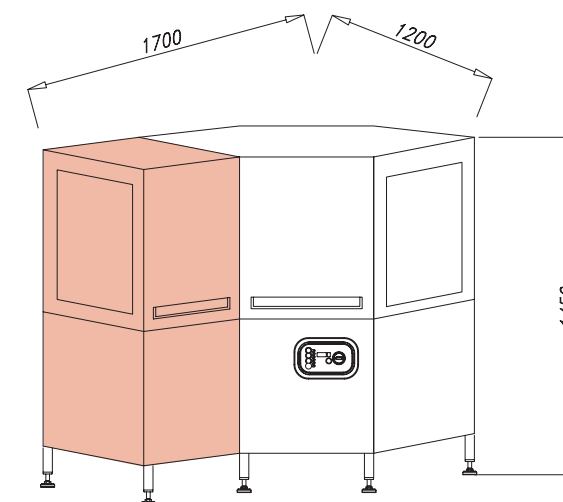

AC2AP - Corner configuration

The pre-wash module measures 500mm in length. The combined action of a recirculating pump and a set of 2 stainless steel embossed arms eliminate the largest food residues on the dishware.

The stainless steel filter, on the surface of the tank, efficiently filters the water.

Whole tank stainless steel filters and safety pump suction filter ensure a higher level of hygiene inside the washing chamber and, therefore, a more effective wash.





## EASE OF USE

The control panel of the AC2 series is practical and resistant to knocks and water spray.

**It is simple to use and and operate: a simple diagnostic with temperature display and alarm codes and a manual selection between 2 speeds.**



**The central stainless steel pawl bar system allows the rack to be accurately centred on the guides!**

**The upper and lower stainless steel washing arms with anti clogging nozzles ensure impeccable washing results every time!**

**The rinsing area, equipped with an economiser, saves water and energy by activating the rinse water flow only when the racks and objects effectively pass through it.**







**Stainless steel washing manifolds with reverse-moulded drip-stop jets and inspection caps.**

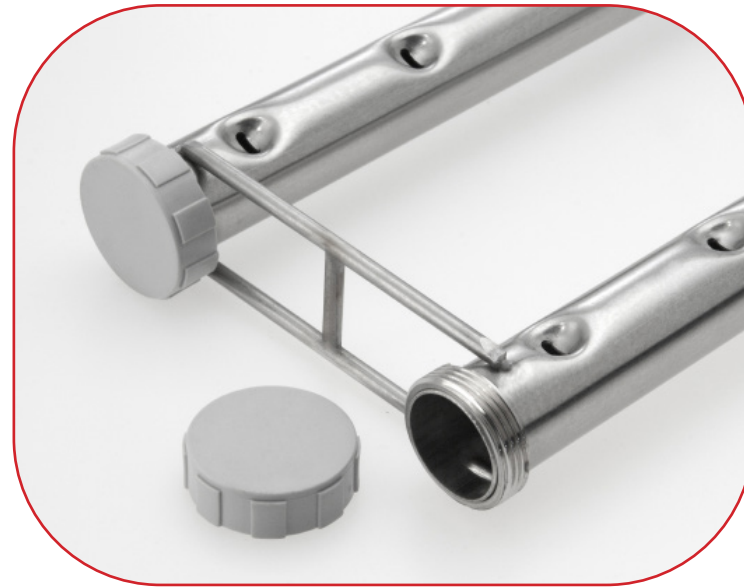

**The smooth-sided moulded tubs, with vertical self-draining pumps outside the tank, ensure perfect hygiene** and prevent the build-up of dirt. The rubber sleeves which connect the pump extraction system to the tank and the input to the pre-wash and washing column help to reduce vibrations.



**The thickness of the insulated and counterbalanced doors guarantees excellent insulation,** minimising the loss of energy and noise level.

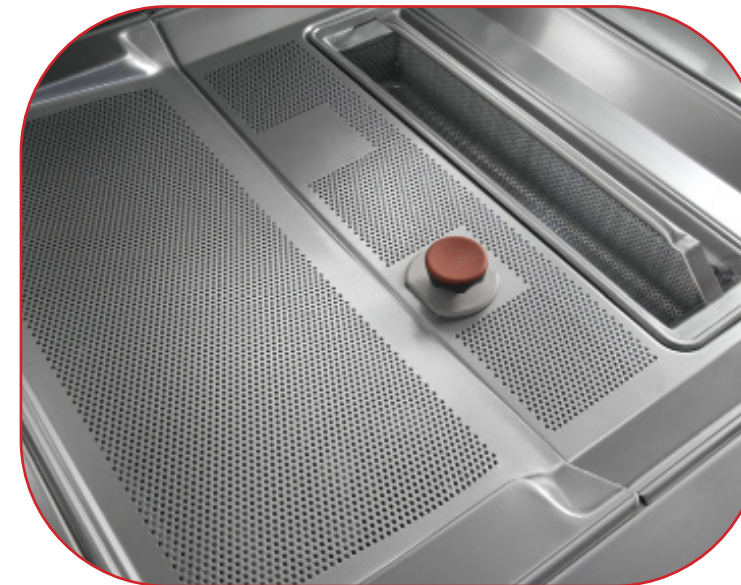

The **double filter system on the surfaces of the tanks** offers greater autonomy during washing operations. The residue is collected by the filter, the water stays clean for longer and the pump power is always guaranteed!

**Integral hooks in the slide guides mean the door is securely fastened, guaranteeing fluid operation at all times.**



**The curtains in non-toxic material** are resistant to detergent and ideal for use in contact with food substances. When placed at the entrance and exit and in the various areas of the machine, they **prevent water splashes and contamination between tubs**; they also help to reduce heat dispersion.







## COLOUR CODING

The Comenda AC2 series has been designed to prevent the build-up of food residue inside the machine, thus guaranteeing a spotlessly hygienic wash result at all times and facilitate daily cleaning operations.

Every module of our tunnel machine - and its internal components- is identified with a colour, for the ease of the staff in cleaning operations and in the process of preparing the machines, avoiding incorrect combinations resulting in malfunctions.

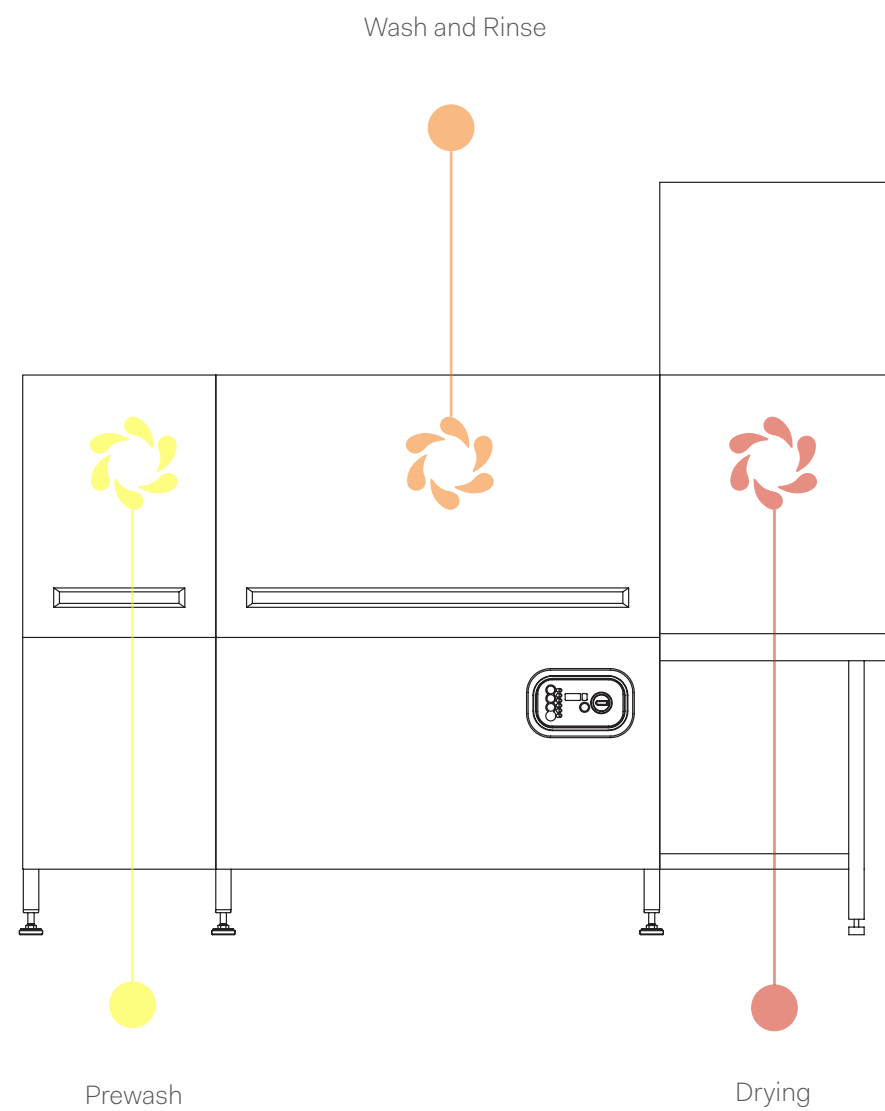





OPTIONAL

## COMPLETE YOUR UNIT

### EOR - EMERGENCY OVERRIDE SYSTEM

Electro-mechanical control with key activation. It allows even unskilled staff to operate the unit in a basic but efficient mode and cope with unexpected PCB failures during operations granting consistency in washing with no downtime. The machine could be then serviced after operations, at customer's convenience.



### AUTOTIMER

Available as an option for AC2 series, this energy saving device automatically puts the unit in standby mode when no racks are detected in the tunnel.



OPTIONAL

## BLOWER DRYERS AND HEAT RECOVERY

### AS - DRYING TUNNEL

600 mm blower drying module is available in straight (AS6) and corner (TC90 - TC180) configurations. The air inside the machine is heated in a battery with heaters and blown on the dishware by means of an upper jet which is adjustable to optimize the result.



Part of the warm air of the dryer is recycled through a suction system within the module and mixed with clean air to decrease humidity, considerably reducing energy consumption.

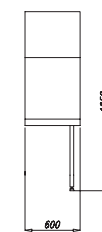

AS6  
600 mm  
AS Blower Dryer

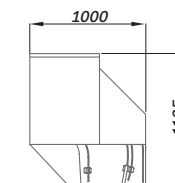

TC90  
TC90 Dryer  
on 90° curve

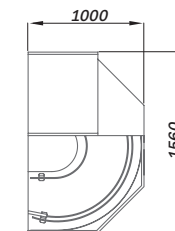

TC180  
TC180 Dryer  
on 180° curve

### RC - HEAT RECOVERY UNIT

Fitted on the rinse section, enables the machine to be connected to cold water at 15°C, which is heated up to 50°C and transferred to the rinse booster. It promotes consistent energy savings.

- -40% ENERGY required to heat rinse water
- Single point air extraction: drastic reduction in the volume of steam released in the work environment by your machine

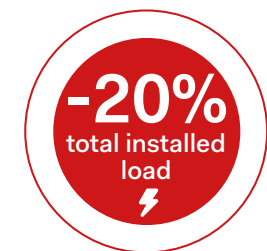

COLD WATER FEED  
15°C





REAL TIME SERVICE

## READY TO RESPOND

There's no time for downtime in your operation. That's why our products are designed to facilitate quick turnarounds and replacements.

By easing access to spare parts through our **Comenda App**, Comenda ensures rapid response and complete client service. For support, count on our extensive network of distributors and service providers who are ready to assist when you need us.



### 01

**Simply scan the QR code** that features on all our machinery to gain 24/7 access to our service platform.

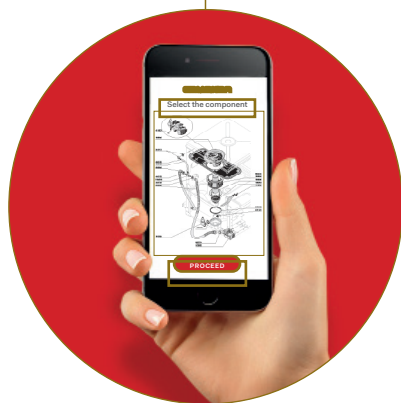
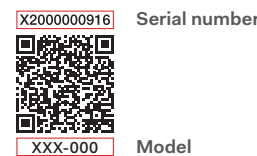

### 02

**Tap into user manuals** as well as detailed electrical and hydraulic schematics, and exploded views.



### 03

**Original spare parts can be easily ordered** by clicking on the exploded view.

Machine spec sheets and CAD drawings are available online in the Comenda Library section at [www.comenda.eu](http://www.comenda.eu)



COMPANY

## COLLABORATIVELY COMENDA

### Just as you are in the business of serving people, we're in the profession of serving you.

Our development since 1963 as a company has always championed exceptional performance, cost containment and highly energy efficient design. Close, active consultation also ensures that we generate the perfect solution for our clients. That involves understanding the challenges our clients face on a daily basis and helping them to meet their objectives.

That's the Comenda difference and it carries on through our commitment to ongoing service and support.

We may be just one component of your overall success, but we always aim to be at the heart of your operation.



RESEARCH & DEVELOPMENT

## A CONTINUOUS CYCLE OF IMPROVEMENT

We have a responsibility to push ourselves to improve. Every detail of Comenda equipment undergoes ongoing scrutiny, testing and refinement.

Through our Research & Development team and certified on-site lab we uphold rigorous scientific principles to develop proven solutions. We draw on the expertise of multidisciplinary engineers and steel industry professionals along with an extensive network of sales managers and distributors who clearly understand client challenges to ensure our equipment performs to the highest calibre.

Teamed with our ongoing customer consultation we can directly address specific issues. That approach may exceed common expectations in this industry, but it demonstrates our commitment to providing superior client service and a stronger overall relationship.



COMENDA srl

Comenda complies with ISO9001 quality management system and ISO14001:2015 environmental management system.







## TECHNICAL DATA

# AC2/AC2P

## Rack conveyor dishwashers

### TECHNICAL DATA

	AC2 AC2A	AC2P AC2AP
MIN. CAPACITY - 1 <sup>st</sup> speed - DIN10534 (racks/h)	70	100
CAPACITY - 2 <sup>nd</sup> speed - (racks/h)	100	150
RINSE WATER CONSUMPTION* (l/rack)	2,2	2
WASH TANKS VOLUME (liters)	80	125
TOTAL MACHINE LENGTH (mm)	1150 1200 x 1200	1450 1200 x 1700
INSTALLED LOAD ● (Kw)	19,03	23,93
INSTALLED LOAD (WITH HEAT RECOVERY UNIT) ● (Kw)	22,08	27,98
INSTALLED LOAD ● (Kw)	31,03	39,83

\* The data refer to the maximum machine capacity

● Warm water connection (55°C)

● Cold water connection (15°C)

All models available in electric or steam heating execution.

## FEATURES

	STANDARD	OPTIONAL
Entry splash shield		●
<b>Counterbalanced insulated doors</b>	●	
Reinforced insulation		●
<b>Autotimer</b>		●
<b>RAH</b> - Rinse aid homogenise		●
<b>RCD</b> - Rinse Control Device		●
<b>AS6</b> - 600 mm Blower dryer – +6,42 Kw/9,42Kw		●
<b>RC</b> - Heat recovery unit		●
<b>TC90</b> - Blower Dryer on 90° 1000x1000 mm exit curve - +6,42 Kw/9,42 Kw		●
<b>TC180</b> - Loyer Dryer on 180° 1500x1000 mm mm exit curve- +6,54 Kw/9,54 Kw		●
<b>Col water feed execution</b>		●
<b>Sanitising system</b>		●
Liquid detergent/rinse aid/sanitizing agent injector		●
Marine execution		●
Special voltages		●



## CONTACTS

### Comenda

Via Galileo Galilei 8

20051 Cassina de' Pecchi (MI)  
Italy

T +39 02 952281

[sales@comenda.eu](mailto:sales@comenda.eu) [www.comenda.eu](http://www.comenda.eu)







an Ali Group Company



The Spirit of Excellence