



XESW-03HS-EDDN

Project _____

Item _____

Quantity _____

Date _____

Model
BAKERLUX SPEED.Pro™

- Convection oven
- Electric
- 3 trays 460x330 (BAKE)
- Drop-down door opening
- 6" Touch control panel
- 1 tray 450x330 (SPEED)



DESCRIPTION

BAKERLUX SPEED.Pro™ is the world's first and only speed baking oven: a convection oven and a speed baking oven in a single piece of equipment. Thanks to the large baking chamber of the BAKERLUX SPEED.Pro™, you can use the Bake mode to bake up to 3 460 x 330 trays of bakery or pastry products, even frozen ones, obtaining perfectly uniform results. The Speed mode allows you to cook and regenerate food, in single or multiple portions, in record time thanks to the combination of controlled hot air flows, microwave technology and the special Speed.Plate baking tray that transmits heat by contact, perfectly toasting all bread-based products.

STANDARD COOKING FEATURES

Manual cooking

- **Temperature:** 30 °C – 260 °C
- Up to 9 cooking steps
- 24 fast programs (12 Speed and 12 Bake)

Programs

- 384 programs Bake
- 384 programs Speed
- **CHEFUNOX:** choose something to cook from the library and the oven will automatically set all the parameters (Bake)
- **SPEEDUNOX:** choose something to cook from the library and the oven will automatically set all the parameters (Speed)

STANDARD TECHNICAL FEATURES

- Stainless steel AISI 304 cooking chamber
- Baking chamber with integrated tray supports
- Visual display of the baking status by means of multicoloured LEDs
- Crumb collection system integrated in the filter under the door
- Proximity door contact switch
- **Wi-Fi / USB data:** download/upload HACCP data
- **Wi-Fi / USB data:** download/upload programs

ADVANCED AND AUTOMATIC COOKING FEATURES

Unox Intelligent Performance

- **ADAPTIVE.Cooking™:** automatically regulates the cooking parameters to ensure repeatable results
- **SMART.Preheating:** sets automatically the temperature and the duration of the preheating
- **AUTO.Soft:** manages the heat rise to make it more delicate

Unox Intensive Cooking

- **SPEED.Plus:** generates microwaves and distributes them evenly throughout the baking chamber
- **DRY.Plus:** extracts humidity from the cooking chamber
- **AIR.Plus:** multiple fans with reverse gear and 2 speed settings

Data Driven Cooking

- Control and monitor the operating conditions of your ovens in real-time, create and share new recipes. The AI transforms the consumption data into useful information in order to increase your daily profit. Create, understand, improve

APP & WEB SERVICES

- Data Driven Cooking app & webapp
- Top Training app
- Combi guru app



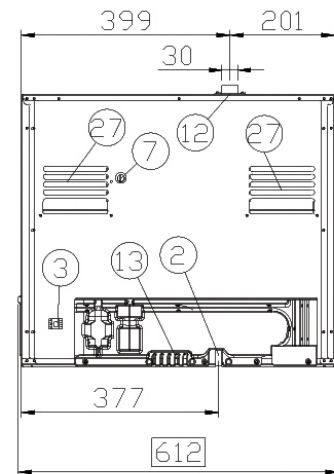
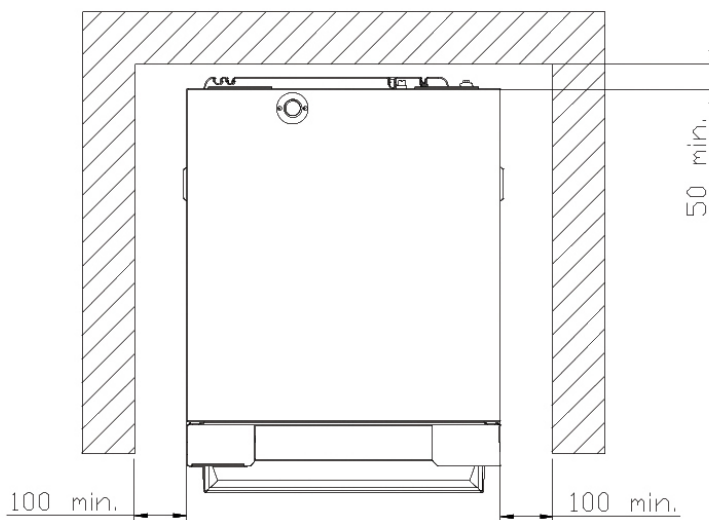
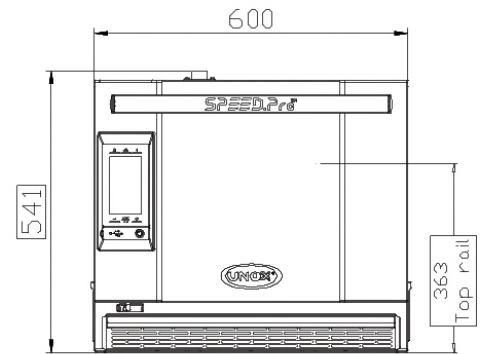
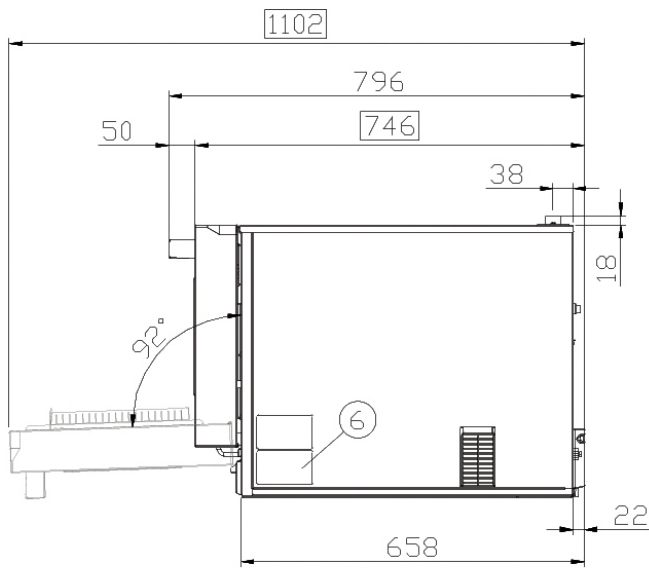

DIMENSIONS AND WEIGHT

| | |
|-------------|--------|
| Width | 600 mm |
| Depth | 797 mm |
| Height | 523 mm |
| Net Weight | 89 kg |
| Pan spacing | 75 mm |

CONNECTION POSITIONS

| | | | |
|---|-----------------------------|----|---------------------------|
| 2 | Terminal board power supply | 12 | Hot fumes exhaust chimney |
| 3 | Unipotential terminal | 13 | Accessories connection |
| 6 | Technical data plate | 27 | Cooling air outlet |
| 7 | Safety thermostat | | |

POWER SUPPLY

STANDARD

| | |
|-------------------------|---------------|
| Voltage | 380-415V V |
| Phase | ~3PH+N+PE |
| Frequency | 50 Hz |
| Total power | 6.6 kW |
| Maximum Amp Draw | 14 A |
| Required breaker size | 16 A |
| Power cable requirement | H07RN-F 5G 5G |
| Cord diameter | 13 mm |
| Plug | NOT INCLUDED |

OPTION A

| | |
|-------------------------|---------------|
| Voltage | 220-240V V |
| Phase | ~3PH+PE |
| Frequency | 50 Hz |
| Total power | 6.6 kW |
| Maximum Amp Draw | 26.5 A |
| Required breaker size | 32 A |
| Power cable requirement | H07RN-F 4G 4G |
| Cord diameter | 13 mm |
| Plug | NOT INCLUDED |

OPTION B

| | |
|-------------------------|---------------|
| Voltage | 220-240V V |
| Phase | ~1PH+N+PE |
| Frequency | 50 Hz |
| Total power | 6.6 kW |
| Maximum Amp Draw | 29.5 A |
| Required breaker size | 32 A |
| Power cable requirement | H07RN-F 3G 3G |
| Cord diameter | 13 mm |
| Plug | NOT INCLUDED |

ACCESSORIES

- **SPRAY&Rinse:** Practical spray detergent to manually clean all kinds of oven. Degreases and removes all kind of dirt
- **Baking Essentials:** special trays for BAKE mode
- **Speed Essentials:** special trays and spatulas for SPEED mode
- **Ethernet:** Connection board to keep the oven connected to Unox and DDC.App
- **Wi-Fi:** Connection board to keep the oven connected to UNOX cloud mandatory to extend warranty

INSTALLATION REQUIREMENTS

Installations must comply with all local electrical systems, particularly as for minimum wire gauge required for field connection, hydraulic and ventilation supply. Exhaust and fume analysis must be performed in case of gas ovens.

Register to access data and product specifications
infonet.unox.com

