



TM tagliaverdure vegetable cutters



- Realizzazione in lega di alluminio e acciaio inox
- Motore ventilato per uso continuo
- Design estremamente compatto per una migliore gestione degli spazi in cucina
- L'esclusivo sistema a caduta diretta del prodotto permette di lavorare anche prodotti morbidi e delicati come mozzarella e altri formaggi
- Sicurezza garantita da 3 microinterruttori: su leva, coperchio e vasca
- Vasca raccoglifette con interblocco in dotazione
- Disponibile con coperchio inox lavabile in lavastoviglie

Opzionale

- Ampia disponibilità di dischi per tutte le applicazioni.
- Stampo pulizia dischi PS
- Porta dischi
- Scicolo per scarico continuo

- *Aluminium alloy and S/S construction*
- *Ventilated motor for continuous operation*
- *Thanks to its compact design the machine is easy to install inside every kitchen*
- *The exclusive feeding system makes easy to process also soft products like mozzarella cheese*
- *Safe operation is ensured by interlock switches on product pusher, lid and collecting tray*
- *Bath collect-interlock provided*
- *Version with dishwashing safe S/S lid available*

Optional

- *Large number of discs available for every purpose*
- *Cleaner for PS discs*
- *Discs holder*
- *Chute for continuous product ejection*



TM ALL



TM INOX



Optionals

Dischi fette Slices discs

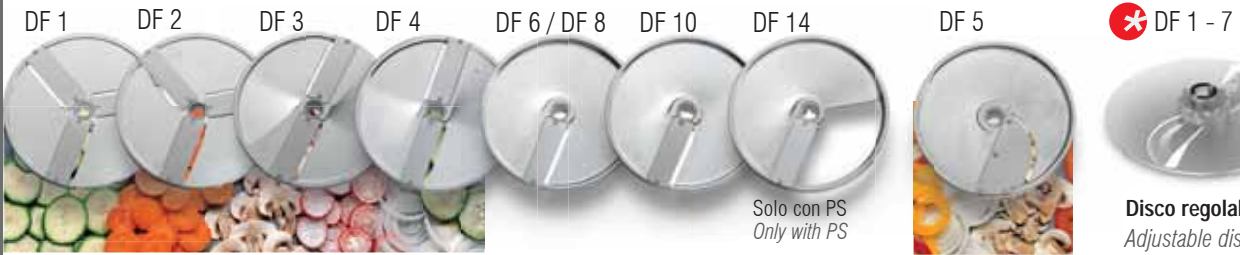

Solo con PS
Only with PS

Disco regolabile
Adjustable disc

Dischi bastoncini Discs sticks



Dischi cubetti Dicing discs



Dischi PS da usare solo in abbinata con i DF PS discs only use with DF

Dischi per sfilacciare Discs for shredding



Dischi grattugia Grating discs

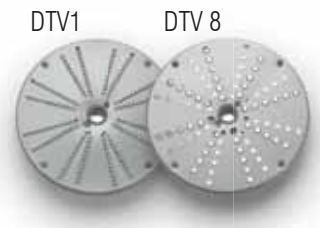

Dischi cubetti Dicing discs

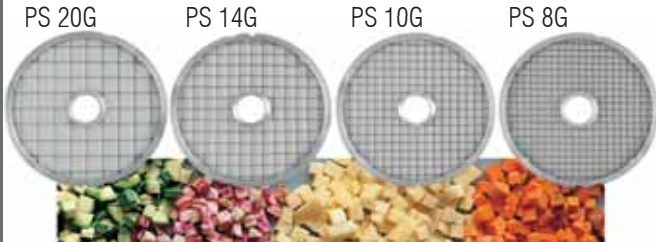

Dischi brunoise Brunoise discs



V-CUT / TM / TM-TG

TM-TG

V-CUT



Pulitore per dischi PS opzionale
Optional cleaner for PS discs



Porta dischi opzionale
Optional discs holder

DF 1-7

Innovativo disco regolabile DF1-7 che permette di tagliare fette di spessore da 1 a 7 mm a piacere
The innovative DF1-7 adjustable disc allows you to cut slices of thickness from 1 to 7 mm as desired



TM / TM-TG / V-CUT

Scivolo per scarico continuo, con micro di sicurezza opzionali

Chute for continuous product ejection, with safety microswitch, optional

TM INOX / TM ALL

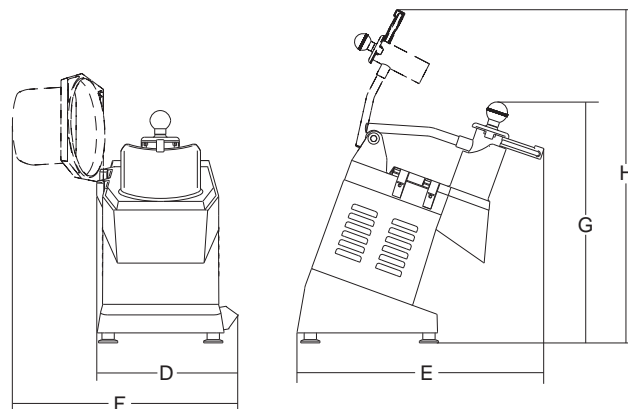
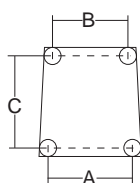
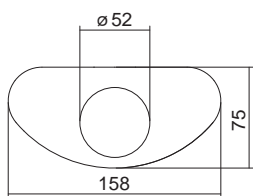

TM-TG

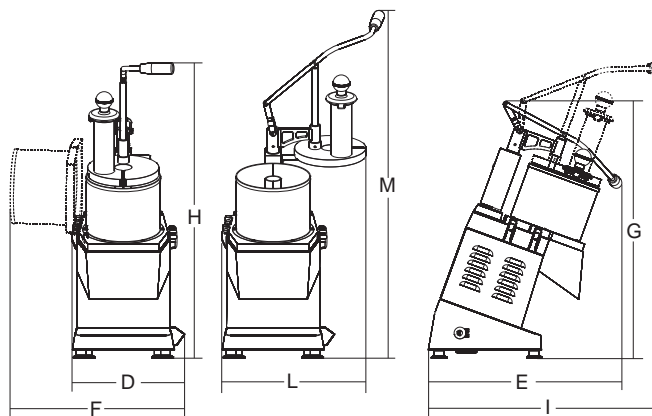
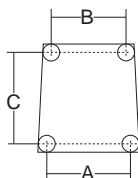
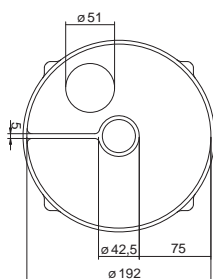

V-CUT

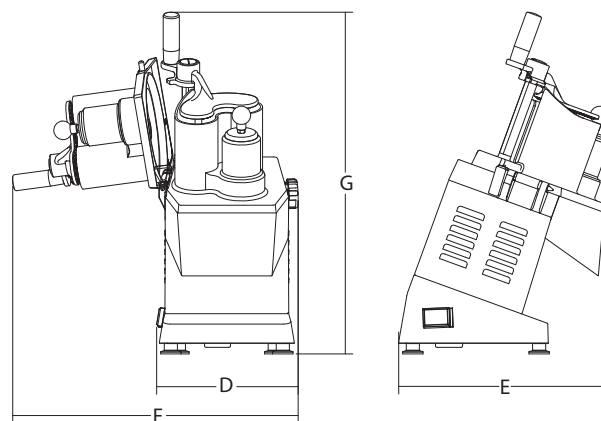
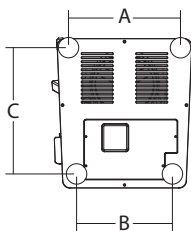
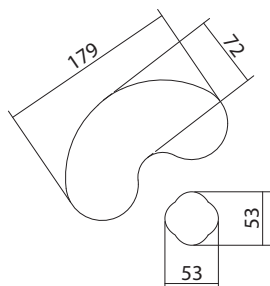

				A	B	C	D	E	F	G	H	I	L	M			
	watt/HP	r.p.m.	r.p.m.	mm	mm	mm	mm	mm	mm	mm	mm	mm	mm	mm	kg	mm	kg
TM Inox	515/0.7	1ph/3ph	300	225	195	255	280	510	400	510	770	-	-	-	18.5	720x350x500	22
TM All	515/0.7	1ph/3ph	300	225	195	255	280	510	400	510	770	-	-	-	18.5	720x350x500	22
TM-TG	515/0.7	1ph/3ph	300	225	195	255	296	509	460	676	777	612	428	915	20	570x750x1050	34
V-CUT	515/0.7	1ph/3ph	300	225	195	255	280	418	566	678	-	-	-	-	-	-	-