

Stainless Steel Stock Pot

Low Pressure

SP 1



SP 2



Ring Burner



High Pressure

SP 1-HP



SP 2-HP



Pineapple Burner

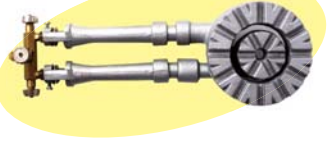

High Pressure

SP 1-HT



SP 2-HT



Trumpet Burner

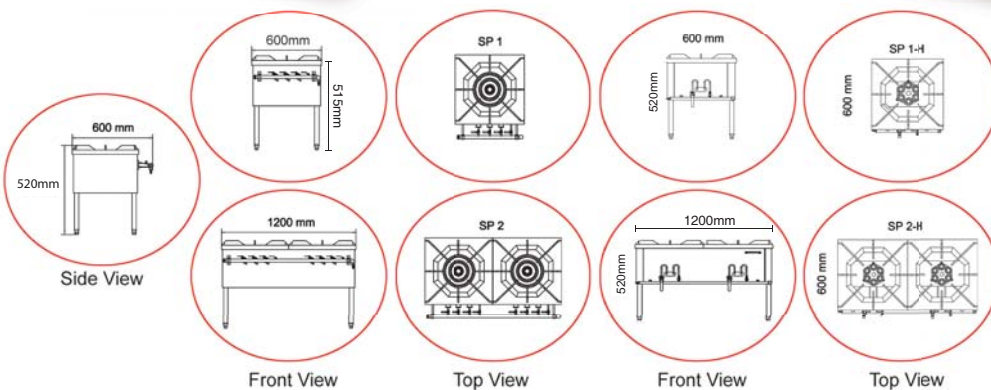

Model	Product Dimension (L x W x H) (mm)	Packing Dimension (L x W x H) (mm)	Weight (kg)	Gas Consumption Btu/Hr (MJ/Hr)	Gas Pressure	Burner Type
SP 1	600 x 600 x 520	655 x 750 x 350	40	56,000 (59)	LOW	Ring
SP 2	1200 x 600 x 520	1220 x 750 x 350	79	112,000 (118)	LOW	Ring
SP 1-HP	600 x 600 x 520	655 x 750 x 350	37	57,000 (60)	HIGH	Pineapple
SP 2-HP	1200 x 600 x 520	1220 x 750 x 350	71	114,000 (120.8)	HIGH	Pineapple
SP 1-HT	600 x 600 x 520	655 x 750 x 350	35	96,000 (101.7)	HIGH	Trumpet
SP 2-HT	1200 x 600 x 520	1220 x 750 x 350	69	192,000 (203)	HIGH	Trumpet

- Staines steel body.
- Cast iron top grate.
- Precision brass gas cork.
- 4 adjustable legs.
- Drip pan is easily removable for cleaning. (except HT model)
- For ring burner, each ring with independent control. (model SP1,SP2,SP1-HP,SP2-HP).
- Real gas connection.