

# 700 700 Pizza



## Characteristics



- A Refrigeration unit**  
Sparblock plug-in - monobloc ventilated system
- B Evaporator**  
Treated by cataphoresis, 316L stainless steel coil
- C Controllore**  
Capacitative touch
- D Door**  
Self-closing 110° opening, removable double chamber magnetic gasket
- E Insulation thickness**  
60mm - HFO polyurethane (no CFC, no HCFC)
- J Floor support**  
Stainless steel feet, galvanised steel bottom panel

- K Rounded corners/removable parts**  
For easy cleaning
- M Rack pitch**  
Adjustable
- P Interchangeable doors and drawers**

# Technical drawing and set-up

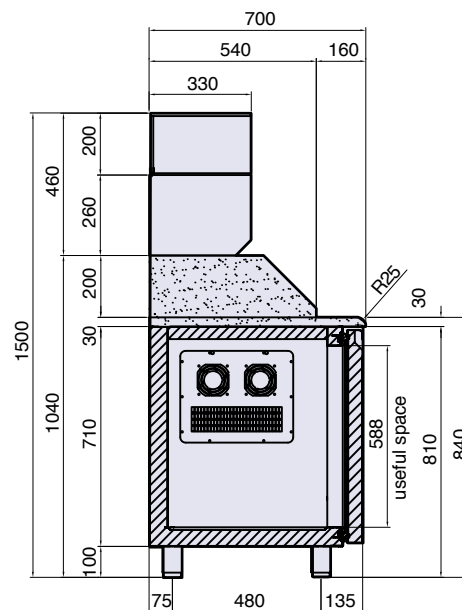
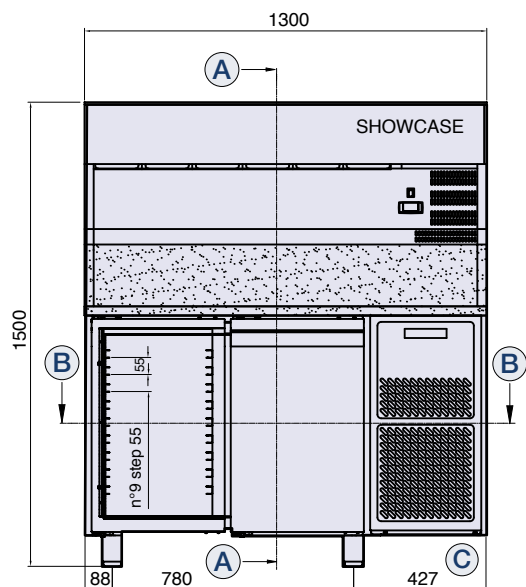

**A-A**

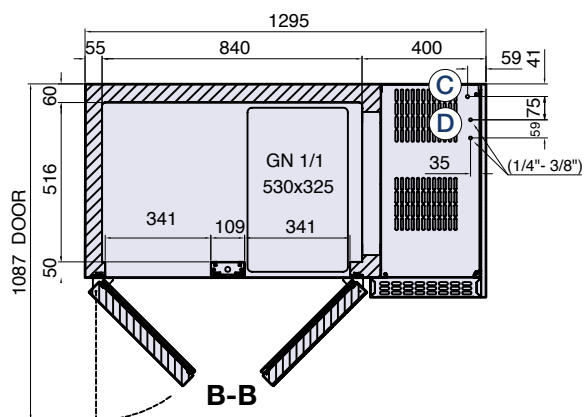

**B-B**

**A Section plane**

**B Section plane**

**C Power cable outlet (length 2 m)**



WARNING! While installing, have a qualified electrician connect it to an electrical panel.

**D Gas pipes outlet**

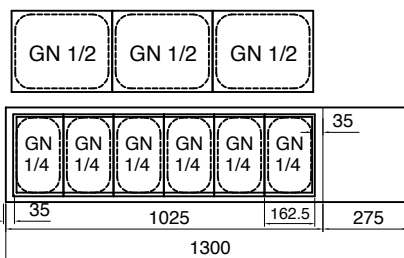
Prepared for remote motor



## Technical specifications

<b>Temperature (°C)</b>	
<b>Model</b>	<b>BPCP702XX</b>
<b>Doors</b>	
<b>Dimensions (mm)</b> L x D x H	1300 x 700 x 1040
<b>Packaging (mm)</b> L x D x H	1370 x 800 x 1400
<b>Refrigerant</b>	
<b>Absorption (W)</b>	318
<b>Voltage (V-Hz)</b>	230-1 50/60Hz
<b>Net weight (kg)</b>	204
<b>Gross weight (kg)</b>	219
<b>Capacity (l)</b>	300

## Available optionals

- Internal light
- Galvanised wheel kit
- Cable with non-standard plug
- Condensate evaporation electrical kit

