

GN 1/1

600x400 STANDARD

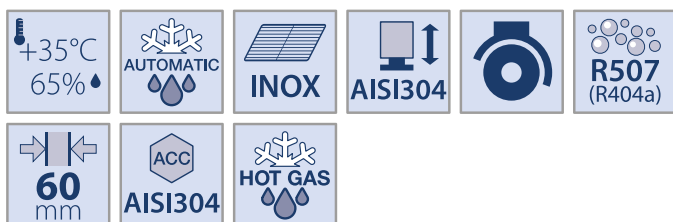

Characteristics



- A Refrigeration unit**
Sparblock plug-in - monobloc ventilated system
- B Evaporator**
Treated by cataphoresis, 316L stainless steel coil
- D Door**
Reversible right/left opening, self-closing 110° opening, removable double chamber magnetic gasket
- E Insulation thickness**
60mm - HFO polyurethane (no CFC, no HCFC)
- F Internal finish**
AISI 304 stainless steel
- J Floor support**
Stainless steel feet, galvanised external bottom panel

- M Rack pitch**
Adjustable

Technical drawing and set-up

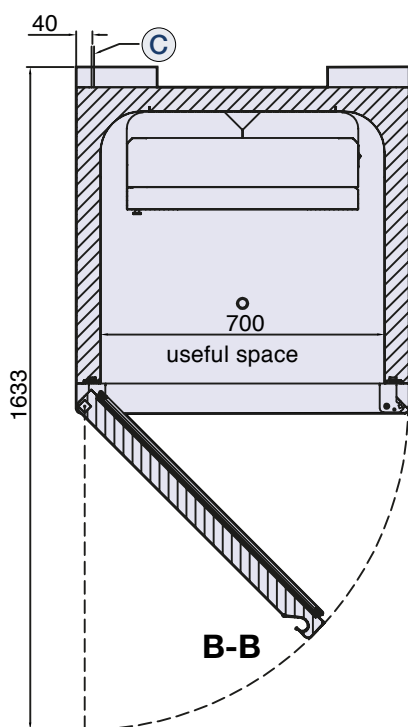
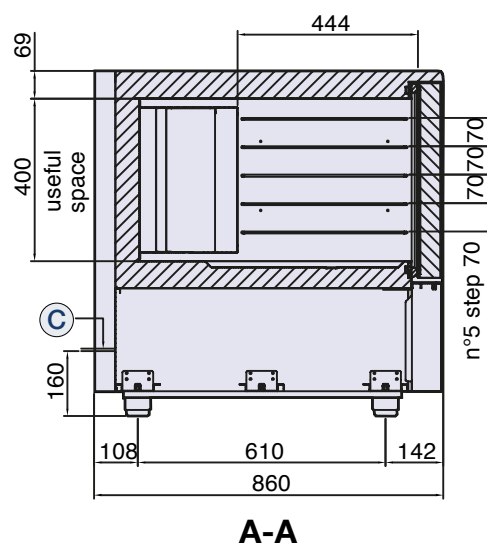
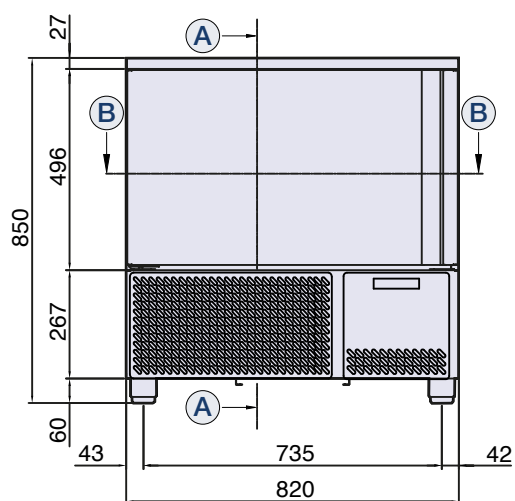

A Section plane

B Section plane

C Power cable outlet (length 2 m)

WARNING! While installing, have a qualified electrician connect it to an electrical panel.

D Minimum distances

WARNING! The distance from hot appliances (e.g. fryers or ovens) must be at least 50 cm.

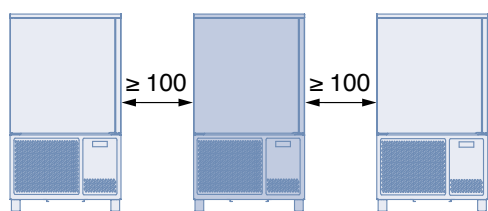

Technical specifications

Model	PBCN51164+70XX	PBCN51164+90XX
Dimensions (mm) L x D x H	820 x 860 x 850	820 x 860 x 850
Packaging (mm) L x D x H	850 x 900 x 1005	850 x 900 x 1005
Absorption (W)	820	900
Voltage (V-Hz)	230-1 50Hz 230-1 60Hz	230-1 50Hz 230-1 60Hz
Net weight (kg)	111	111
Gross weight (kg)	121	121
Rapid chilling performance	20 Kg +70°/+3°	20 Kg +90°/+3°
Freezing performance	13 Kg +70°/-18°	13 Kg +90°/-18°
Performance (W)	1460/630	1460/630
Load capacity of the trays	5 tray GN1/1 5 grids 600x400	5 tray GN1/1 5 grids 600x400

