

# 700 PLUS



## Characteristics



- A Refrigeration unit**  
Sparblock plug-in - monobloc ventilated system
- D Door**  
Reversible right/left opening, self-closing 110° opening
- E Insulation thickness**  
60mm - HFO polyurethane (no CFC, no HCFC)
- F Internal finish**  
AISI 304 stainless steel
- J Floor support**  
Stainless steel feet, galvanised external bottom panel
- K Rounded corners/removable parts**  
For easy cleaning

- O Worktop**  
AISI 304
- Q Interchangeable doors and drawers**

# Technical drawing and set-up

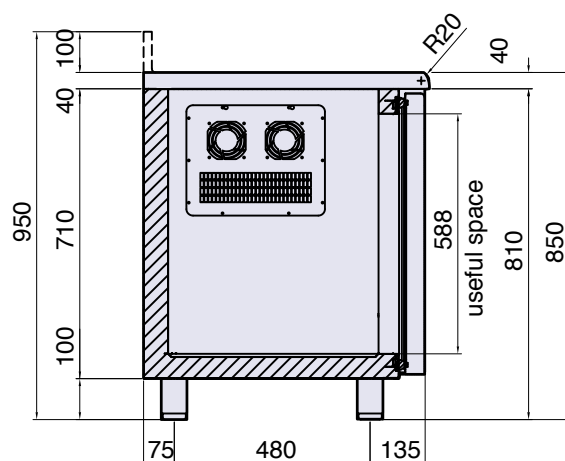
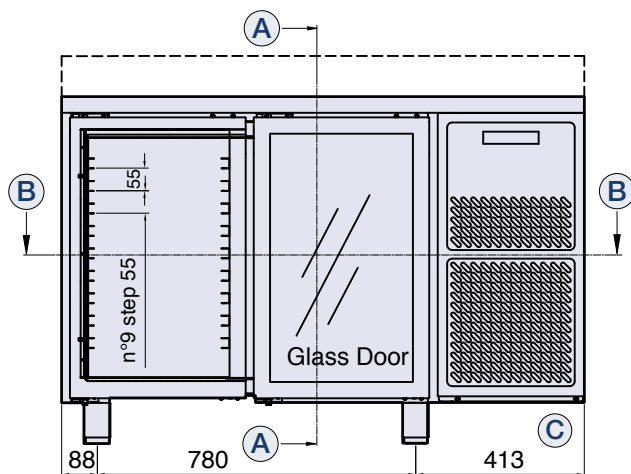



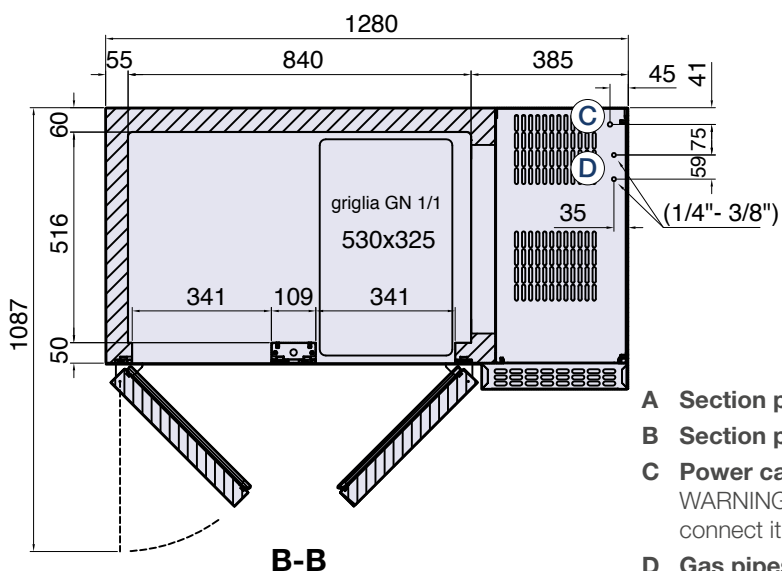

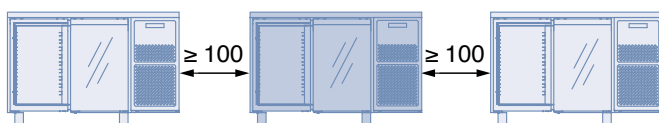

**A-A**



- A Section plane**
- B Section plane**
- C Power cable outlet (length 2 m)**  
WARNING! While installing, have a qualified electrician connect it to an electrical panel.
- D Gas pipes outlet**  
Prepared for remote motor



# Technical specifications

Temperature (°C)	 0/+10	 0/+10
Model	PPCT702GLXX	PPCT702MRGLXX
Doors		
Dimensions (mm) L x D x H	1280 x 700 x 850-900	1280 x 700 x 850-900
Packaging (mm) L x D x H	1320 x 730 x 1100	1320 x 730 x 1100
Refrigerant	 R134a	 R134a
Absorption (W)	318	30
Voltage (V-Hz)	230-1 50/60Hz	230-1 50/60Hz
Net weight (kg)	101	87
Gross weight (kg)	114	100

