

Family
COOKING EQUIPMENT STAR 60

Section
ELECTRIC BAIN - MARIE AND HEATED FOOD CONTAINER

Model
B68E

Code
CR0853500

ELECTRIC BAIN-MARIE

S/s single-phase electric bain-marie. Deep drawn well in polished stainless steel with radiused bottom for ease of cleaning. Etched foil heating elements underneath the tank, with thermostatic temperature control from 30°C to 90°C. Product features perforated false bottom and drain cock. GN compliant well for 2 x GN1/1 bowls with max. height = 150 mm.



Technical data

Width mm:	800	Internal dim. oven mm:	
Depth mm:	600	Oven capacity:	
Height mm:	295	Oven power kW:	
Weight kg.:	23.00	Qty heating zones:	2xGN1/1
Volume m ³ :	0.43	Plate dim. mm:	
Power supply:	VAC230 50Hz	Dim. heating zone mm:	
Gas power kW:		Qty tank:	
Electric power kW:	2.00	Tank dim. mm:	530x650x200h
		Tank capacity l:	9

Family
COOKING EQUIPMENT STAR 60

Section
ELECTRIC BAIN - MARIE AND HEATED FOOD CONTAINER

Model
B68E

Code
CR0853500

ELECTRIC BAIN-MARIE

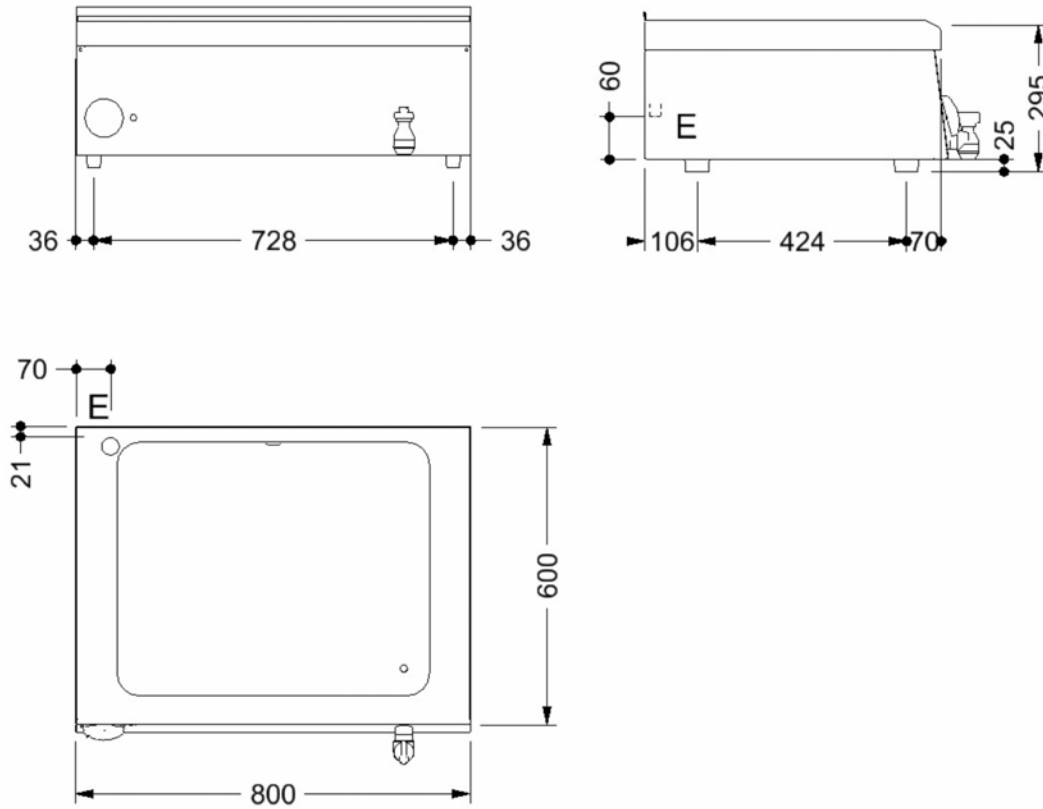

Legend

(E) Socket 1: Connection supply terminal floor level (+100mm). Spare cable 1500mm

(E) Socket 2:

(G) Gas:

(AD) Softened water:

(AF) Cold water:

(AC) Hot water:

(S) Draining:

(FR) In e out freon:

(V) Steam: