

**Family**  
COOKING EQUIPMENT STAR 60

**Section**  
ELECTRIC COOKING RANGES

**Model**  
C67E

**Code**  
CR0853050

## ELECTRIC HOB WITH 4 HOTPLATES

S/s electric hob. With 2 elec. hotplates Ø 220 mm at 2.6 kW and 2 elec. hotplates Ø 180 mm at 1.5 kW. The hotplates are sealed after being fitted and finished with a non-drip edge.



### Technical data

Width mm:	700	Internal dim. oven mm:	
Depth mm:	600	Oven capacity:	
Height mm:	295	Oven power kW:	
Weight kg.:	30.00	Qty heating zones:	2 x 2,6 kW - 2 x 1,5 kW
Volume m <sup>3</sup> :	0.22	Plate dim. mm:	2 x Ø 220 - 2 x Ø 180
Power supply:	VAC400-3N 50Hz	Dim. heating zone mm:	
Gas power kW:		Qty tank:	
Electric power kW:	8.20	Tank dim. mm:	
		Tank capacity l:	

**Family**  
COOKING EQUIPMENT STAR 60

**Section**  
ELECTRIC COOKING RANGES

**Model**  
C67E

**Code**  
CR0853050

**ELECTRIC HOB WITH 4 HOTPLATES**

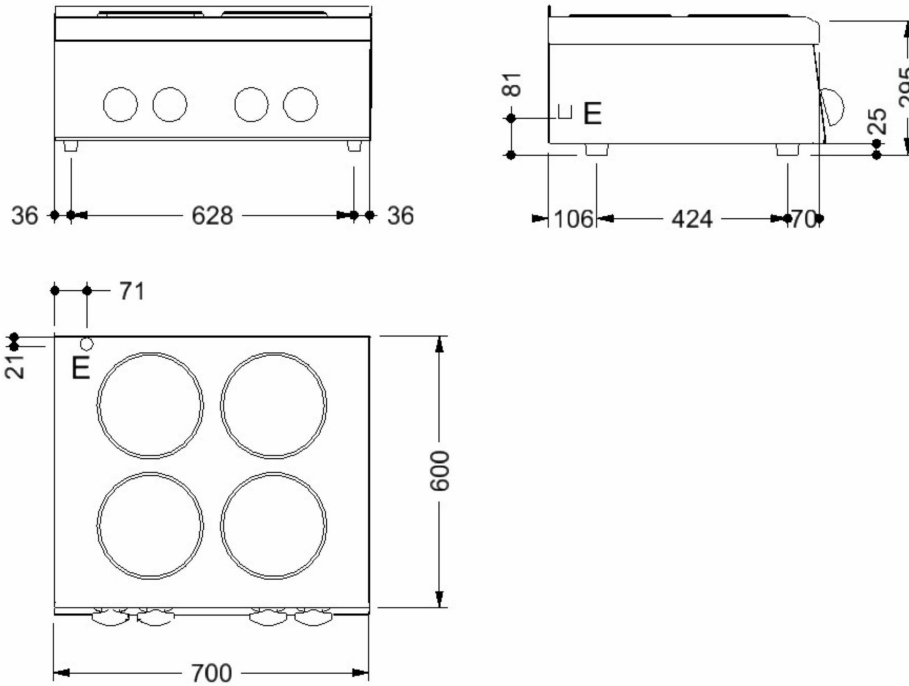

**Legend**

(E) Socket 1: Connection supply terminal floor level (+100mm). Spare cable 1500mm

(E) Socket 2:

(G) Gas:

(AD) Softened water:

(AF) Cold water:

(AC) Hot water:

(S) Draining 1:

(S) Draining 2:

(FR) In e out freon:

(V) Steam: