

Family
COOKING EQUIPMENT STAR 90

Section
GAS WOK RANGES

Model
NW96G10

Code
CR0991690

WOK RANGE WITH 1 X 10KW GAS BURNER

Freestanding wok range featuring a high-yield burner with vertical flame, for uniform heating of the wok and perfectly cooked food. 1 x 10 kW burner in enamelled cast iron measuring Ø 190 mm with venturi system in stainless steel, removable for easy cleaning and maintenance. Cooktop in reinforced AISI 304 stainless steel, thickness 20/10. Power adjustment by means of a safety tap with thermocouple. Main burner ignition by means of a permanent pilot burner. Wok pan stand grille Ø 215 mm manufactured in enamelled cast iron with Ø 410 mm base. Recessed spillage well measuring 550x720 mm and rear drain to right Ø 22 mm equipped for connection to drainage system, option water filling system for cooling and cleaning of top. Removable grease collection tray positioned below burners. Appliance equipped with height adjustable feet in stainless steel.



Technical data

Width mm:	600	Internal dim. oven mm:	
Depth mm:	900	Oven capacity:	
Height mm:	870	Oven power kW:	
Weight kg.:	60.00	Qty heating zones:	1 x 10 kW
Volume m ³ :	0.58	Plate dim. mm:	
Power supply:		Dim. heating zone mm:	
Gas power kW:	10.00	Qty tank:	
Electric power kW:		Tank dim. mm:	
		Tank capacity l:	

Family
COOKING EQUIPMENT STAR 90

Section
GAS WOK RANGES

Model
NW96G10

Code
CR0991690

WOK RANGE WITH 1 X 10KW GAS BURNER

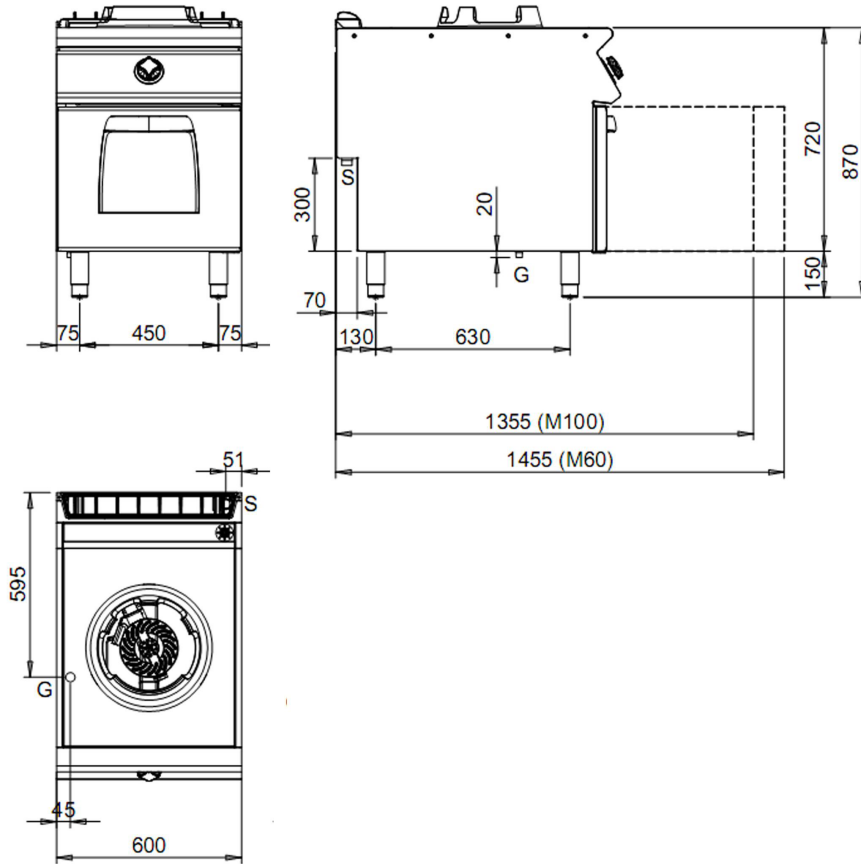

Legend

(E) Socket 1:

(E) Socket 2:

(G) Gas: Ø1/2"- H=200mm

(AD) Softened water:

(AF) Cold water:

(AC) Hot water:

(S) Draining 1:

(S) Draining 2:

(FR) In e out freon:

(V) Steam: