

Family
COOKING EQUIPMENT STAR 90

Section
GAS AND ELECTRIC PASTA COOKERS

Model
NPC98E

Code
CR0590840

42+42 LITRE TWO WELL ELECTRIC PASTA COOKER

Electric pasta cooker with two wells constructed in AISI 304 stainless steel. 2 mm thick pressed top with spillage recess and extended expansion zone. Deep drawn wells in AISI 316 polished stainless steel with radiused bottom for ease of cleaning. Water loading by means of solenoid valve activated by switch on control panel. Fast filling and top-up options. Safety guaranteed by a pressure switch, which prevents heating if well is empty. Fixed water tap in stainless steel located below draining board. Armoured immersion-type heating elements for optimized performance, foldable to facilitate well cleaning. Precise heating control by means of energy regulator. 42+42-litre well capacity. Well dimensions mm 305x510x285h. Drain taps on bottom of well, accessible from front doors. Height adjustable feet in stainless steel. IPX5 protection rating.



Technical data

Width mm:	800	Internal dim. oven mm:	
Depth mm:	900	Oven capacity:	
Height mm:	870	Oven power kW:	
Weight kg.:	82.00	Qty heating zones:	2 x 8,5 kW
Volume m ³ :	1.00	Plate dim. mm:	
Power supply:	VAC400 3N 50Hz	Dim. heating zone mm:	
Gas power kW:		Qty tank:	2
Electric power kW:	17.00	Tank dim. mm:	305x510x285h
		Tank capacity l:	42 + 42

Family
COOKING EQUIPMENT STAR 90

Section
GAS AND ELECTRIC PASTA COOKERS

Model
NPC98E

Code
CR0590840

42+42 LITRE TWO WELL ELECTRIC PASTA COOKER

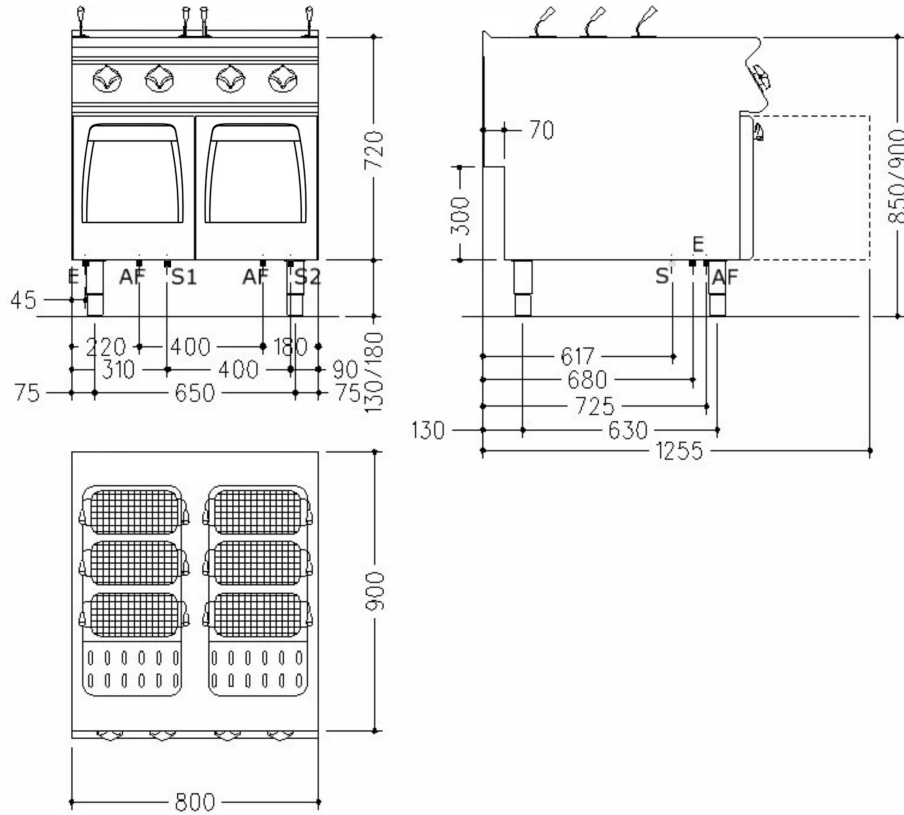

Legend

(E) Socket 1: Connection supply terminal floor level (+100mm). Spare cable 1500mm

(E) Socket 2:

(G) Gas:

(AD) Softened water:

(AF) Cold water: Ø3/4"-H=200mm

(AC) Hot water:

(S) Draining 1: Ø1"-H=200mm

(S) Draining 2:

(FR) In e out freon:

(V) Steam: